

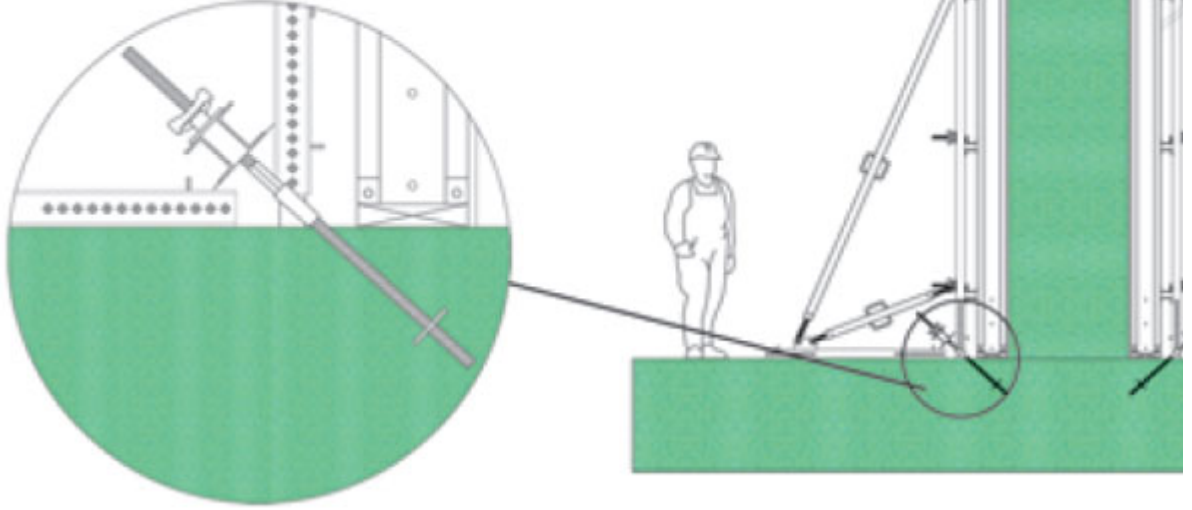











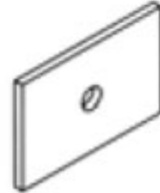

ÜRÜNLER - TIRMANIR KALIP - TEKNİK ÖZELLİKLER

İlk dökülen perde kalıbının tabana ankrajlanarak, kalıbın hareket etmesi şeklindeki gibi önleni döküm gerçekleştirilir ve daha sonra kalıp tırmanma konsolları monte edilir.

> tırmanır kalıp
teknik özellikler

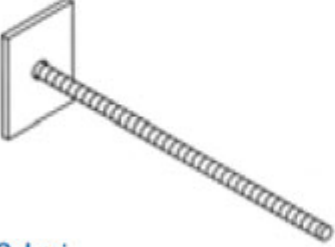
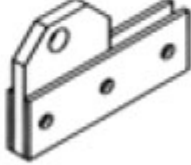

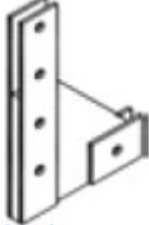
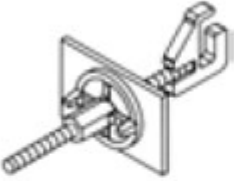
	Referans No.	Boy (mt.)	Ağırlık (kg.)	
 <p>Tırmanma Konsolu</p>	TK 100 TK 101	1.50 2.00	74.00 87.00	 <p>Yer Tutucu</p>
 <p>Aspa Platformu</p>	TK 102	1.50/3.30	29	 <p>Üçgen Anahtar</p>
 <p>Dikey Kuşak Taşıma Plakası</p>	TK 103	-	5.00	 <p>Tırmanma Askısı</p>
 <p>Zig-Zag Ankraj</p>	TK 104 TK 105	15 20	0.90 2.00	 <p>Ankraj Pulü</p>

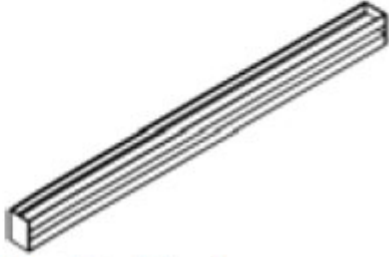
	Referans No.	Boy (mt.)	Ağırlık (kg.)	
	TK 113 TK 114	15 (cm) 20 (cm)	0.70 2.50	
Plastik Kılıf				Payanda Kafası
	TK 115 TK 116 TK 117 TK 118	15x15 15x40 20x25 20x45	1.00 1.50 1.90 2.40	
Kalıta Ankrāj				Payanda Ayağı İkili
	TK 119 TK 120 TK 121 TK 122 TK 123	2.90 3.00 3.30 3.60 3.90	78.50 84.50 90.50 96.50 103.00	
Dikey Kuşak				Dikey- Yatay Kuşak Bağlantı Elemanı
	TK 124	NPU 100	2.50	
Kuşak Kuşa Bağlama Parçası				Taban Yatay Kuşak
	TK 125	-	0.60	
Ankrāj Somunu				Taban Ankrāj Kuşağı

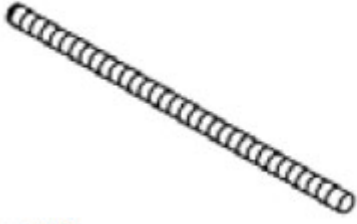

Ankroj Mili

TK 126	15	1.50/m
TK 127	20	1.80/m



Dişi Ankroj